

K-DRIVE

User Manual

Power electronic passive components

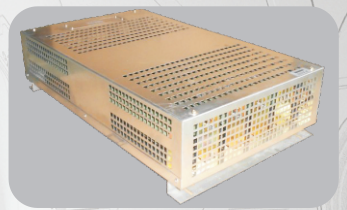
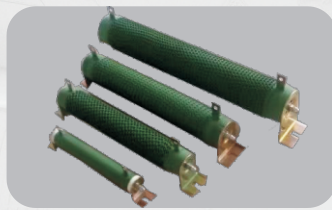

SHENZHEN K-EASY AUTOMATION CO.,LIMITED

COMPANY PROFILE

Shenzhen K-Easy Automation Co., Limited is a professional manufacturer, specialize in R&D And production of AC drives. We have built up a comprehensive product family. Frequency inverters' power covers the range from 0.4 to 630kW, and voltage range is between 220V and 480V. More than inverters are running smoothly 300, 000 units at different industrial sites.

Why Us

- ◆ We believe “quality is life”, so we will test all products before shipment, All Module of our VFD will be used quality is life with Infineon only, With years of persistence, the total failure ratio of Our frequency inverters has been controlled below 1%. We never lose a customer because of the quality problem;
- ◆ With Strong R&D and Engineer Team, makes our after-service very easy, For all doubts and requesting for technologies supporting, We can offer detailed Solution without delay, so for us, “Not Only Products, But also solutions”;
- ◆ All our products will be offered with 24 months Warranty Period instead of 18 months.

Join us, enjoy the business.

COMPANY PROFILE



产品应用及目录

Product application and catalogue

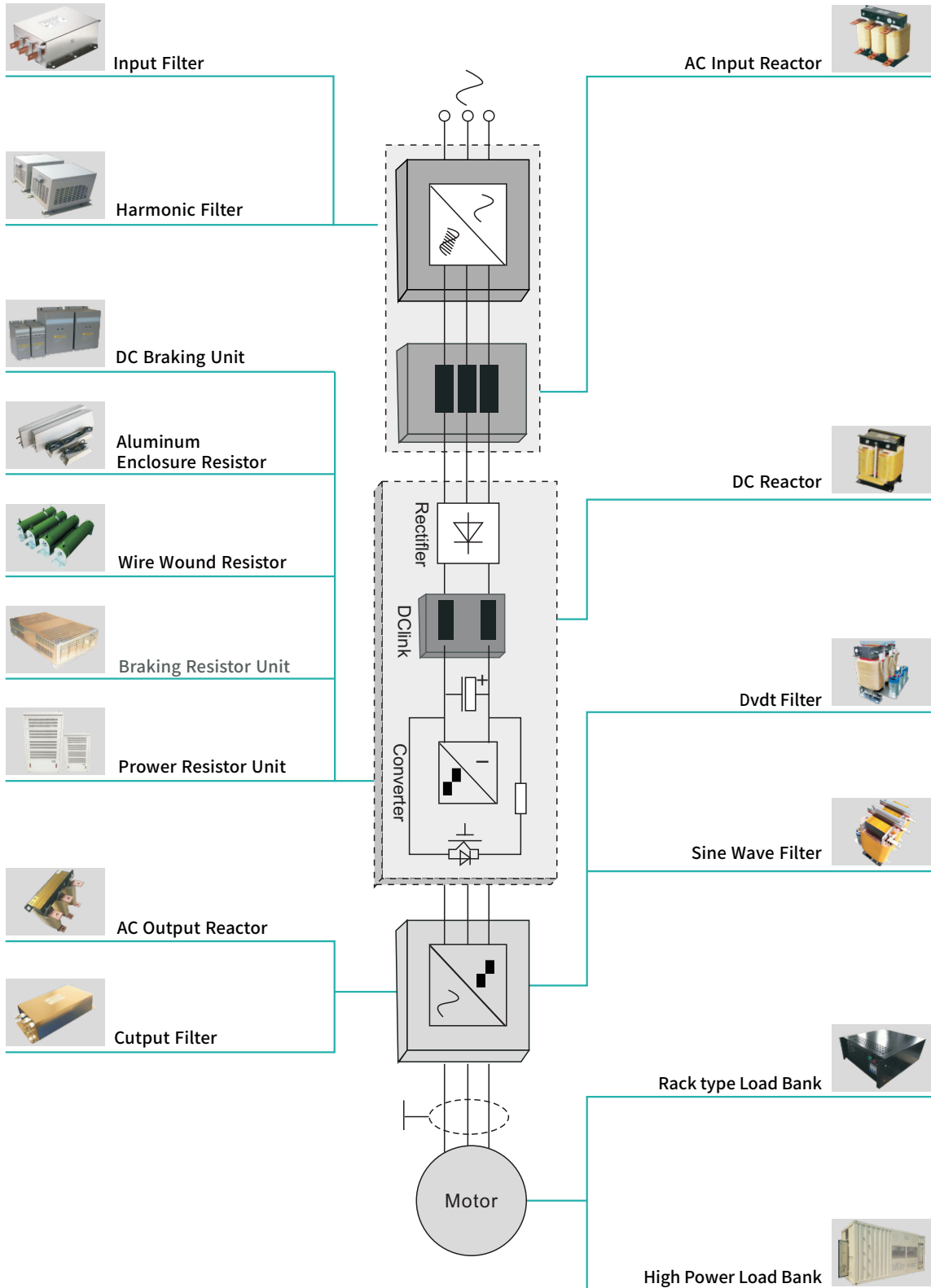

铝壳电阻器(RXLG) Aluminum Enclosure Resistor

■ 产品概述(Product Introduction)

RXLG 系列铝壳绕线电阻器采用铝合金外壳,外形美观,该电阻具有耐气候性、耐振动、安全性优于传统瓷骨架电阻器。RXLG 电阻器是用一种耐高温的有机硅树脂和硅粉作基本材料封装的功率型绕线电阻。易紧密安装,易附加散热器。

RXLG series aluminum shell winding resistor using alloy enclosure, beautiful shape, beautiful shape, the resistance have the weather resistance, vibration resistance security is super to the traditional porcelain skeleton resistor resistor



■ 产品应用(Product Application)

1. 做为制动电阻保护变频器、伺服等不受电机再生电能的危害;
2. 电力电子负载测试中做为阻性负载;
3. 在电力电子设备中做为取样电阻、限流电阻、起动电阻、保护电阻。
 - 1.As a braking resistor to protect the inverters, servos, etc, from damage by regenerative energy of the motor;
 - 2.As a resistive load in power electronic load tests;
 - 3.As a sampling resistor, limiting resistor, starting resistor, or protective resistor in power electronic equipment.

■ 技术规格(Technical Specifications)

1. 电阻值以及变化范围: $1\Omega \leq R \pm 5\%$ (J), $1\Omega > R \pm 10\%$ (K)
2. 温度系数: $R > 20\Omega$, $\pm 260\text{ppm}/^\circ\text{C}$ $R \leq 20\Omega$, $\pm 400\text{ppm}/^\circ\text{C}$ 在 $-25 \sim 200^\circ\text{C}$ 温度下实验
3. 额定负荷: 表面温度 $\leq 375^\circ\text{C}$ 放在 $300 \times 300 \times 3\text{mm}$ 铝板上
4. 短时过载: $\Delta R \leq \pm (2\%R + 0.05\Omega)$ 无异常同样环境下 10 倍额定电压, 5 秒
5. 绝缘电阻: $R \geq 100\text{M}\Omega$ 1min 无异常 DC1000V, 焊片和外壳之间的绝缘电阻要求大于或等于 $100\text{M}\Omega$
6. 耐电压: $\Delta R \leq \pm (0.1\%R + 0.05\Omega)$ 无异常, 无破坏焊片与外壳之间加 AC3000V5S
7. 端子强度: 无松动无异常 100N 力加在焊片引出方向, 30 秒
8. 耐震性: 无可见损伤, $\Delta R \leq \pm (0.1\%R + 0.05\Omega)$ f: 10-55Hz a=1.5g X.Y.Z 各 2h
9. 耐热性: 除端子外无明显变色和损伤, 标志清新加热至 $350 \pm 5^\circ\text{C}$, 120 ± 5 分钟
10. 热冲击: $\Delta R \leq \pm (2\%R + 0.05\Omega)$ 无异常额定电压 30 分钟, 常温, 8-12 秒放到 $-40 \pm 2^\circ\text{C}$ 环境下, 15+5 分钟。再在常温下放置 2 小时
 1. Resistance value and the change range: $1\Omega \leq R \pm 5\%$ (J), $1\Omega > R \pm 10\%$ (K)
 2. Temperature coefficient: $R > 20\Omega \pm 260\text{ppm}/^\circ\text{C}$ $R \leq 20\Omega$, $\pm 400\text{ppm}/^\circ\text{C}$ Test when the temperature is $-25 \sim 200^\circ\text{C}$
 3. Rated load: The surface temperature $\leq 375^\circ\text{C}$ on the $300 \times 300 \times 3\text{mm}$ aluminum plate
 4. Short-time overload: $\Delta R \leq \pm (2\%R + 0.05\Omega)$ No abnormal environment also 10 times the rated voltage, 5 second
 5. Insulation resistance: $R \geq 100\text{M}\Omega$ 1min Without abnormal DC100V, insulation resistance between welding plate and shell is no less than $100\text{M}\Omega$
 6. Withstand voltage: $\Delta R \leq \pm (0.1\%R + 0.05\Omega)$ No abnormal damage welding piece between the shell and AC3000V5S
 7. Terminal strength: Without losing without exception 100n force on welding lead direction, 30 second
 10. Thermal: $\Delta R \leq \pm (2\%R + 0.05\Omega)$ No abnormal voltage rating for 30 minutes, room temperature, 8-12 seconds into $-40 \sim -20^\circ\text{C}$ environment, 15+5 minutes, the place 2 hours at room temperature

■ 执行标准 (Applicable Standards)

GB/T5729-1994 Fixed resistor used in electronic equipment

■ 降额曲线 (Rundown Curve)

环境温度 Ambient temperature	0-20°C	> 20°C
功率损耗 Power loss	100%	See figure

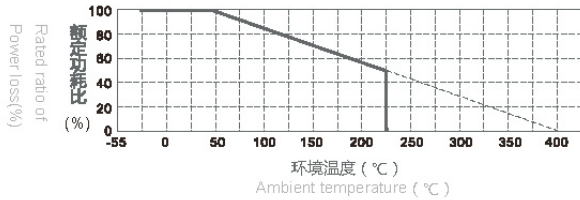

■ 表面升温 (Surface Temperature Rise)

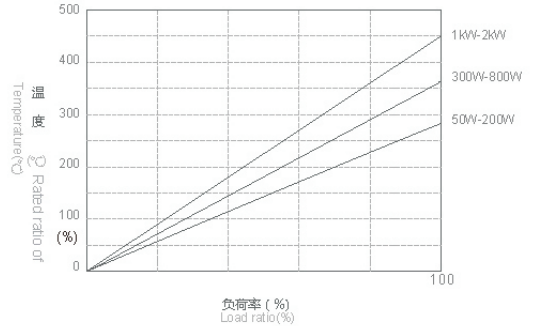

■ 产品尺寸图 (Product Size)

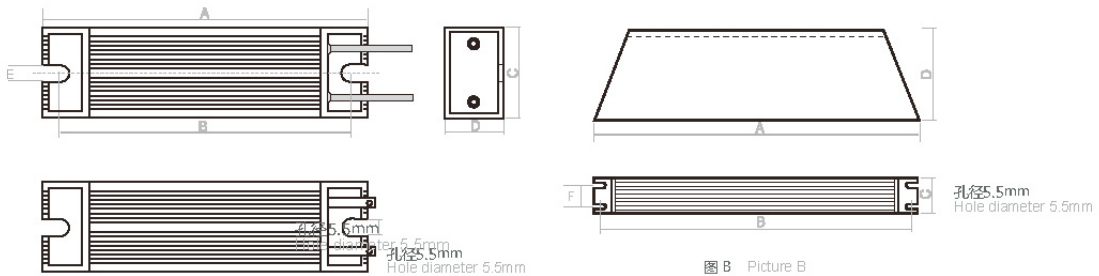

规格 Type	功率 Rated Power (W)	图号 Picture	尺寸/Dimension(mm)					配线(mm²)	引线长度 length (mm)	端子
			A	C	D	B	F			
RXLG	60	Picture A	115	40	20	98	*	1	500	M5
RXLG	80		140	40	20	123	*	1	500	M5
RXLG	100		165	40	20	148	*	1	500	M5
RXLG	120		190	40	20	173	*	1	500	M5
RXLG	150		215	40	20	197	*	1	500	M5
RXLG	200		165	60	30	147	*	1.5	500	M5
RXLG	300		215	60	30	197	*	1.5	500	M5
RXLG	400		265	60	30	247	*	1.5	500	M5
RXLG	500		335	60	30	317	*	1.5	500	M5
RXLG	800		Picture B	400	61	59	385	40	2.5	500
RXLG	1000	400		50	107	385	30	端子引出		M6
RXLG	1200	450		50	107	435	30	端子引出		M6
RXLG	1500	485		50	107	470	30	端子引出		M6
RXLG	2000-3000	550		50	107	535	30	端子引出		M6
RXLG	3500-4000	700		50	107	685	30	端子引出		M6

备注: 其他规格尺寸, 可根据用户要求制造。Remark: Dimension can be customization

■ 产品选择指引 (Selection guide)

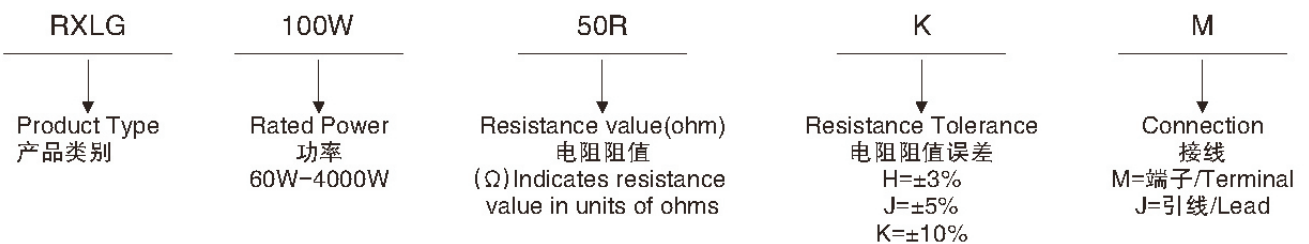

波纹电阻器(RXHG) Wire Wound Resistor

■ 产品概述(Product Introduction)

RXHG型涂料绕线电阻器是一种功率型绕线电阻器,该产品采用波状电阻合金带以侧立形式缠绕在陶瓷骨架上,表面被覆绝缘耐高温涂料,有利于散热,并配有安装支架,电阻器具有功率大,耐过载能力强,安装方便等特点。

RXHG coatings type winding resistor is a kind of power mode,the product use the wave resistance alloy in the form of side winding on the ceramin matrix The surface coating insulation resistance to high temperature coating,is conducive to heat dissipation,and is equipped with a mounting bracket,a resistor has large power,strong overload capacity resistance,convenient installation and other feature

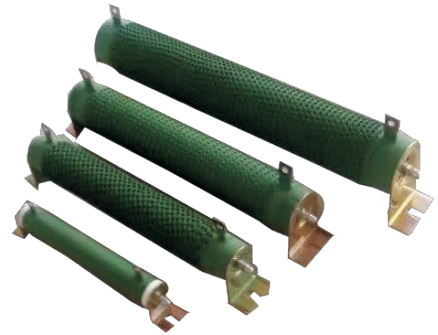

■ 产品应用(Product Application)

1. 做为制动电阻保护变频器、伺服等不受电机再生电能的危害
2. 电力电子负载测试中做为阻性负载
3. 在电力电子设备中做为取样电阻、限流电阻、起动电阻、保护电阻
- 1.As a braking resistor to protect the inverters,servos,etc,from damage by regenerative energy of the motor;
- 2.As a resistive load in power electronic load tests;
- 3.As a sampling resister,limiting resistor,starting resistor,or protective resistor in power electronic equipment.

■ 技术规格(Technical Specifications)

1. 阻值及阻值允许偏差: $1\Omega \leq R \pm 5\%$ (J), $1\Omega > R \pm 10\%$ (K)
2. 额定负荷: 表面最高温度: $50 \sim 200W \leq 275^\circ C$, $> 200W$ 小于等于 $350^\circ C$
3. 短时过负荷: 无可见损伤, $\Delta R \leq \pm (5\%R + 0.05\Omega)$ 10倍 5s
4. 绝缘电阻: $R \geq 100M\Omega$ 1min DC 1000V
5. 耐电压: 无可见损伤, 无飞弧击穿 $\Delta R \leq \pm (0.1\%R + 0.05)$ AC 3000V 5S
6. 电阻温度特性: $\pm 260PPM/^\circ C$ (小于 5Ω 以不作检测)
7. 端子强度: 无松动或机械损伤 45N 30S''
8. 电阻体强度: 无可见损伤 200N 30S
9. 耐振性: 无可见损伤, $\Delta R \leq \pm (0.1\%R + 0.05\Omega)$ f:5-200Hz a=1g X.Y.Z各 2h
10. 耐热性: 除端子外无明显变色和损伤, 标志清晰 $350^\circ C$ 2hours
11. 热冲击: 无可见机械损伤 额定负载 30 分钟后 $-55^\circ C$ 温度下 15min
12. 耐湿性: 无可见损伤, 标志清晰, $\Delta R \leq \pm (5\%R + 0.05\Omega)$
绝缘电阻 $\geq 10M\Omega$ DC100 $40^\circ C$ 95%RH 500hours
13. 耐久性(额定负载): 外观无可见损伤, 标志清晰, $\Delta R \leq \pm (5\%R + 0.05\Omega)$ 100% 负荷
- 1.Resistance value and the change range: $1\Omega \leq R \pm 5\%$ (J), $1\Omega > R \pm 10\%$ (K)
- 2.Rated load:The maximum surface temperature, $50 \sim 200W \leq 275^\circ C$, $> 200W \leq 350^\circ C$
- 3.Short-time overload:No visible damage $\Delta R \leq \pm (5\%R + 0.05\Omega)$ 10 times 5s
- 4.Insulation resistance: $R \geq 100M\Omega$ 1min DC 1000V
- 5.Withstanding voltage :No visible damage,no arcing breakdown $\Delta R \leq \pm (0.1\%R + 0.05)$ AC 3000V 5S
- 6.Resistance-temperature characteristic: $\pm 260PPM/^\circ C$ (less than 5Ω don't test)
- 7.Terminial strength No looseness or mechanical damage 45N 30s
- 8.Resistance strength No visible damage 200N 30S
- 9.Withstanding vibration:No visible damage $\Delta R \leq \pm (0.1\%R + 0.05\Omega)$ f:5-200Hz a=1g X.Y.Z/2h
- 10.Heat resistance:In addition to the terminal no pbvious discoloration and damage,marked clearly $350^\circ C$ 2hours
- 11.Heat shock No visible mechanical damage,after 30minute rated overload
- 12.Wateriogging resistance:No visible mechanical damage,marked clearly $\Delta R \leq \pm (5\%R + 0.05\Omega)$ Insulation resistance $\geq 10M\Omega$ DC100 $40^\circ C$ 95%RH 500hours
- 13.Durability(rated overload):No visible damage,marked clearly $\Delta R \leq \pm (5\%R + 0.05\Omega)$ load 100%

■ 执行标准 (Applicable Standards)

GB/T5729-1994 Fixed resistor used in electronic equipment

■ 降额曲线 (Rundown Curve)

环境温度 Ambient temperature 0-20°C > 20°C

功率损耗 Power loss 100% See figure

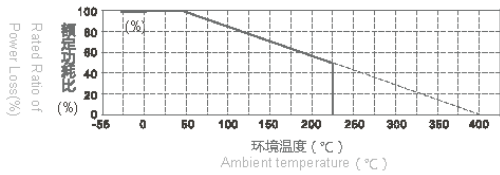

■ 表面升温 (Surface Temperature Rise)

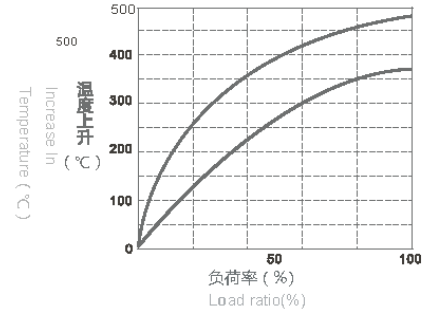

■ 产品尺寸图 (Product Size)

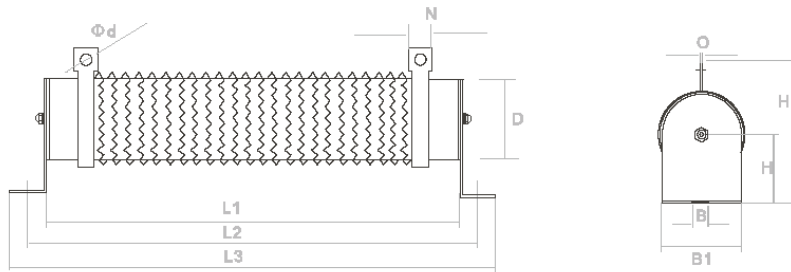

额定功率 (W)	L1 (±2)	L2 (±5)	L3 (±3)	D (±2)	B	B1	H1 (±3)
50	102	124	146	28	6.5	28	62
60	102	124	146	28	6.5	28	62
80	152	174	196	28	6.5	28	62
100	182	204	226	28	6.5	28	62
120	182	204	226	28	6.5	28	62
150	195	217	239	40	8	40	87
200	195	217	239	40	8	40	87
300	282	304	326	40	8	40	87
400	282	304	326	40	8	40	87
500	316	338	360	50	8	50	99
800	316	338	360	60	8	50	99
1000	300	325	350	60	8.5	60	119
1200	300	325	350	60	8.5	60	119
1500	415	440	465	60	8.5	60	119
2000	510	535	560	60	8.5	60	119
2500	600	625	650	60	8.5	60	119
3000	600	635	660	68	8.5	68	130
4000	600	635	660	68	8.5	68	130
5000	500	535	560	100	8.5	100	160
6000	600	635	660	100	8.5	100	160

备注: 其他规格尺寸, 可根据用户要求制造。Remark: Dimension can be customization

■ 产品选择指引 (Selection guide)

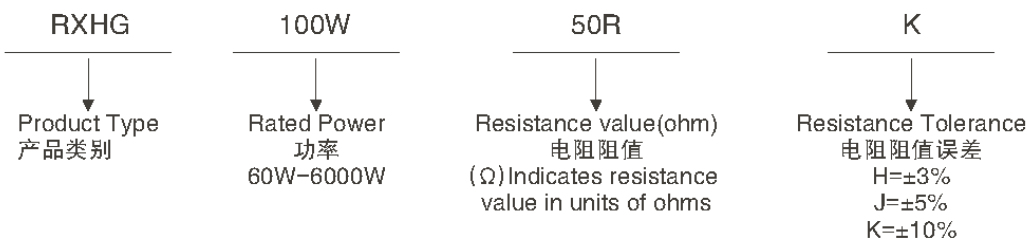

制动电阻箱 (BRU) Braking Resistor Unit

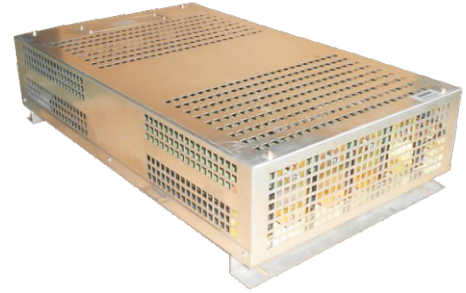

产品概述 (Product Introduction)

BRU 系列产品是由制动电阻器组合而成的电阻箱, 适用于大功率、大电流的制动设备、实验测试设备, 电梯、起重等变频器的能耗制动回路中。

功率范围: 0.5KW-25KW

电压范围: 0.5KV-3KV

防护等级: IP20-IP43

振动: 0.5G

BRU series products are resistance boxes composed of brake resistors, suitable for high-power, high-current braking equipment, experimental testing equipment, elevators, cranes and other inverter energy consumption braking loop.

Power range: 0.5KW-25KW

Voltage range: 0.5KV-3KV

Protection level: IP20-IP43

Vibration: 0.5 G

产品尺寸图 (Product Size)

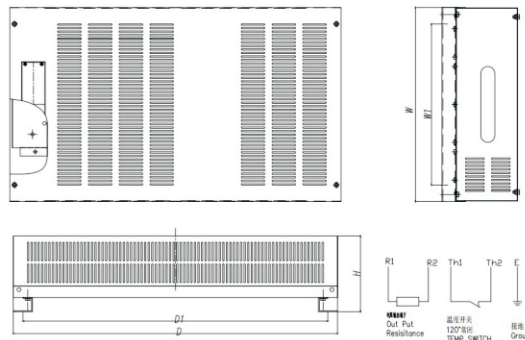

型号 Type	功率 Rated Power (KW)	尺寸/Dimension(mm)					端子 Terminal	重量 Weight (Kg)
		W	D	H	D1	W1		
BRU	1	160	500	170	480	120	M6	5
	1.5	160	500	170	480	120	M6	6
	2	280	500	170	480	240	M6	8
	3	280	500	170	480	240	M6	10
	4.5	340	600	170	580	290	M6	12
	6	340	600	170	580	290	M6	14
	8	410	685	170	665	340	M6	16
	10	410	685	170	665	340	M6	18
	15	410	685	170	665	340	M6	22
20-25	410	685	340	665	340	M6	36	

产品选择指引 (Selection guide)

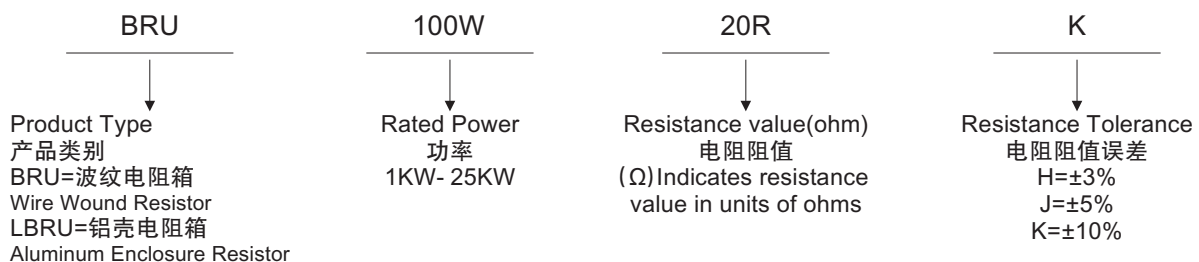

功率电阻柜 (PRU) Power Resistor Unit

■ 产品概述 (Product Introduction)

PRU 系列产品是由制动电阻器组合而成的电阻柜, 适用于大功率、大电流的制动设备、实验测试设备, 电梯、起重等变频器的能耗制动回路中。

功率范围: 20KW-1000KW

电压范围: 0.5KV-3KV

防护等级: IP20-IP44

振动: 0.5G

PRU series products are resistance cabinets composed of brake resistors, which are suitable for high-power and high-current braking equipment, experimental testing equipment, elevator, crane and other inverter energy consumption braking loop.

Power range: 20KW-1000KW

Voltage range: 0.5KV-3kV

Protection level: IP20-IP44

Vibration: 0.5 G



■ 产品尺寸图 (Product Size)

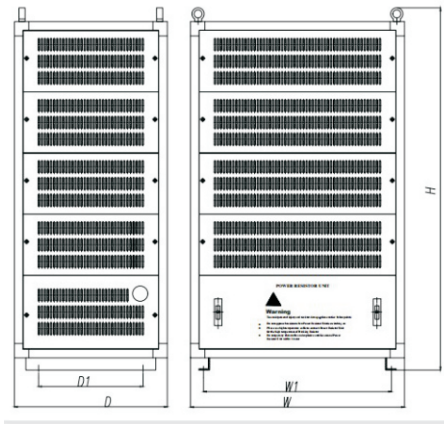

型号 Type	功率 Rated Power (KW)	尺寸/Dimension(mm)						端子 Terminal	重量 Weight (Kg)	组合 Combination
		W	D	H1	H	D1	W1			
PRU	20	700	500	500	650	342	615	M6	60	8*2.5KW
	30	700	500	700	850	342	615	M6	75	12*2.5KW
	40	700	500	900	1050	342	615	M6	86	16*2.5KW
	50	700	500	1100	1250	342	615	M6	100	20*2.5KW
	60	700	500	1300	1450	342	615	M6	115	24*2.5KW
	70	700	500	1500	1650	342	615	M6	130	28*2.5KW
	80	700	500	1600	1750	342	615	M6	140	32*2.5KW
	100	700	500	1800	1950	342	615	M6	165	40*2.5KW
	120	700	500	2000	2150	342	615	M6	200	48*2.5KW
200	700	1000	2000	2150	842	615	M6	330	2*100KW	

■ 产品选择指引 (Selection guide)

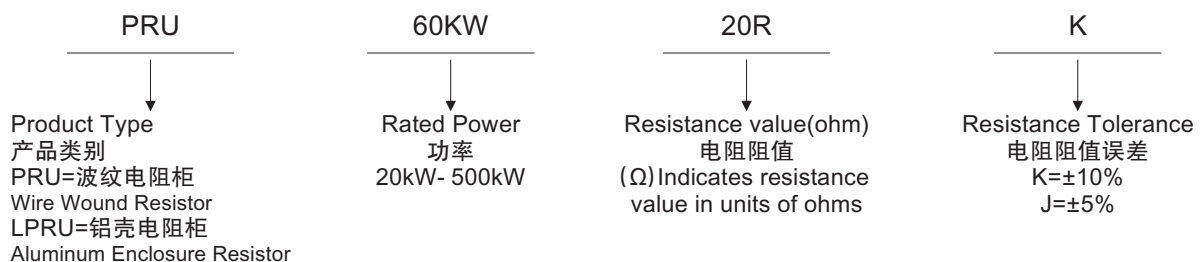

制动单元(CDBR) DC Braking Unit

产品概述(Product Introduction)

采用在变频器直流侧设置制动单元组件,将再生电能消耗在功率电阻上来实现制动。通过专门的能耗制动控制电路将再生能量消耗在电阻上,转化为热能。

The function of the braking unit is to divert into a brake resistor the re-generative energy produced in the process of decelerating the motor, converting that energy into heat. Regenerative energy flows from the motor into the inverter DC bus, manifested as increased bus voltage.



产品应用(Product Application)

变频器在减速时,由于拖动系统的惯性较大,此时电动机处于发电状态,机械能快速回馈到直流母线上,使直流母线电压迅速上升,从而危及变频器的安全,因此必须将该回馈能量迅速消耗掉,否则变频器将会过压保护或故障。一般惯性较大,或需急剧减速,刹车的场合可使用本制动单元。例如:离心机,电梯,起重机,拉丝机,港口机械等均可使用。When the inverter slows down, the motor is in the state of power generation because of the large inertia of the dragging system, and the mechanical energy quickly feeds back to the DC bus, making the DC bus voltage rise rapidly, thus endangering the safety of the converter. Therefore, the feedback energy must be consumed quickly, otherwise the converter will be overvoltage protection or fault. General inertia is large, or need to slow down sharply, braking occasions can use this braking unit. For example: centrifuge, elevator, crane, drawing machine, port machinery and so on can be used.

产品尺寸图(Product Size)

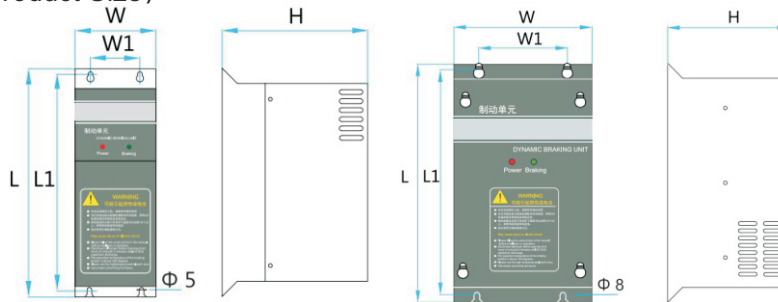

产品型号 Product Type	额定电流 Rated Current(A)	峰值电流 Crest Current	最小阻值 Minimum Resistance	尺寸/Size(Unit:mm)					端子 Terminals	图号
				L	L1	W	W1	H		
CDBR-2015	15A	50A	10Ω	240	228	85	55	153	M4	图一
CDBR-2022	25A	75A	6.8Ω	240	228	85	55	153	M4	
CDBR-2030	30A	85A	5Ω	240	228	85	55	153	M4	
CDBR-4030	15A	50A	20Ω	240	228	85	55	153	M4	
CDBR-4045	25A	75A	13.6Ω	240	228	85	55	153	M4	
CDBR-4055	30A	85A	12Ω	240	228	85	55	153	M4	
CDBR-4075M	35A	100A	10Ω	240	228	85	55	153	M4	
CDBR-4075	35A	100A	8Ω	320	304	187	120	163	M6	图二
CDBR-4110	50A	150A	6.8Ω	320	304	187	120	163	M6	
CDBR-4160	70A	200A	5Ω	320	304	187	120	163	M6	
CDBR-4220	85A	300A	3.3Ω	320	304	187	120	163	M6	
CDBR-4300	120A	400A	2.5Ω	320	223	193	304	160	M6	

产品选择指引 (Selection guide)

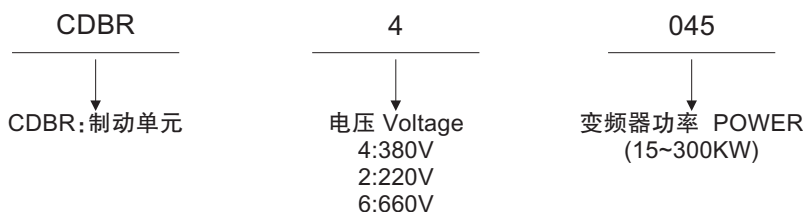

交流输入电抗器(ACL) AC Input Reactor

■ 产品概述(Product Introduction)

进线电抗器可被用于给线路电源提供改进的过载保护,并能减小变频器产生的电流谐波失真。提高输入电源的功率因素,减少高次谐波,抑制变频器在电源设备上的浪涌。

Input reactors offer overload to line power supply and reduce harmonic distortion arising from frequency inverters,also improve the input supply,reduce ultraharmonic and suppress the surge caused by frequency inverters to the power supply units.



■ 产品应用(Product Application)

特别在下列环境下推荐使用进线电抗器:

1. 几个变频器并联紧密连接
2. 线路电源有来自其他设备的明显扰动(干扰,过电压)
3. 线路电源各相之间存在电压不平衡,超过额定电压的1.8%
4. 在同一线路上安装有大量的变频器
5. 减小COS ϕ 校正电容器上的过载,如果装置中含有一个功率系数校正设备

Particularly apply to the following cases:

1. Multiple frequency inverters in close parallel connection
2. Other devices produce interference to line power supply,(disturbance,over voltage)
3. Nonbalance among phases of line power supply,1.8% over than of the rated voltage
4. Massive frequency inverters installed on the same line
5. Reduce cos ϕ and correct the overload of capacitor,in case the power factor correction devices are installed in system

■ 技术规格(Technical Specifications)

工作电压 Work Voltage:	220VAC-3300VAC
工作频率 Work Frequency:	50/60Hz
工作电流: Work Current:	3A-1600A
绝缘等级 .Insulation Class:	class F,H
防护等级 .Protection Class:	IP00-IP22
压降 Voltage drop:	< 4% 大于此范围会引起转矩损失
最大电流 Max Current:	1.5X 额定电流,持续 60S
噪音 Noise:	≤65dB
温升 Temperature Rise:	≤85K
抗电强度 Dielectric strength:	铁芯-绕组 3000VAC/50HZ/5MA/10S 无飞弧击穿(工厂测试)
绝缘电阻 Insulation Resistor:	1000VDC 绝缘阻值≥100MΩ

使用环境: -10~+45°C, 额定值不会降低。最高可达+55°C, 在45°C以上。

每升高1°C, 额定电流降低2%, 海拔高度不超过2000米。

运行环境温度 -25°C~+45°C, 相对湿度不超过90%。

周围无有害气体, 无易燃易爆物品。

周围环境应有良好的通风条件, 如装在柜内, 应加装通风设备。

Operation Environment: -10~+45°C, rated value won't lower, when higer than 55°C, and every 1°C, the current will step down 2%, Under seal level 2000m

Running ambient temperature -25°C~+45°C, comparative moisture moisture not over 90%

No hazardous gas, no inflammables and explosives

With well-ventilated condition, ventilation devices shall be mounted if installation in panels

■ 执行标准 (Applicable Standards)

IEC289:1987 Reactor GB10229-88 Reactor(eqvIEC289:1987)
 JB9644-1999 Reactors used for semiconductor electrical driving

■ 产品尺寸图 (Product Size)

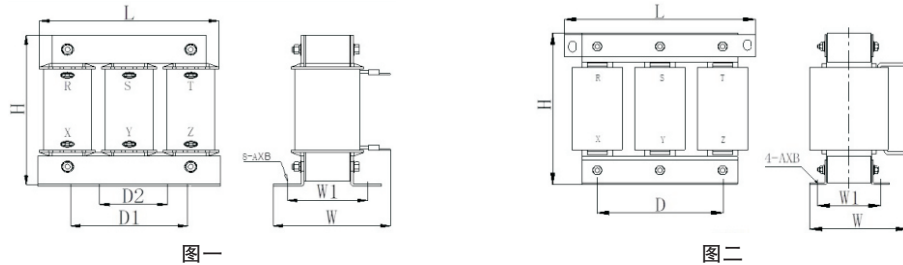

型号 Type	电流 Rated Current (A)	电感量 Induc-tance Value (mH)	压降 Voltage Drop	适配变频器功率 Power (KW)	图号 Picture	尺寸 Dimension(mm)					
						L (max)	W (max)	H (max)	D1 ± 2	W1 ± 3	4-AXB
ACL-0005-2M80-0.4SC	5	2.8	2%	1.5	图一	120	110	120	65	60	6X15
ACL-0008-2M00-0.4SC	8	2	2%	2.2		120	110	120	65	60	6X15
ACL-0010-1M40-0.4SC	10	1.4	2%	3.7		120	110	120	65	60	6X15
ACL-0015-0M94-0.4SC	15	0.94	2%	5.5		120	110	120	65	60	6X15
ACL-0020-0M70-0.4SC	20	0.7	2%	7.5		155	140	140	95	73	6X15
ACL-0030-0M47-0.4SC	30	0.47	2%	11		155	140	140	95	73	6X15
ACL-0040-0M36-0.4SC	40	0.36	2%	15		155	150	140	120	78	6X15
ACL-0050-0M28-0.4SC	50	0.28	2%	18.5		195	160	165	120	85	8.5X20
ACL-0060-0M24-0.4SC	60	0.24	2%	22		195	160	165	120	85	8.5X20
ACL-0080-0M18-0.4SC	80	0.18	2%	30		195	160	175	120	85	8.5X20
ACL-0090-0M16-0.4SC	90	0.16	2%	37		195	170	175	120	92	8.5X20
ACL-0120-0M12-0.4SC	120	0.12	2%	45		195	180	190	120	105	8.5X20
ACL-0150-094U-0.4SC	150	0.094	2%	55		195	180	190	120	105	8.5X20
ACL-0120-0M12-0.4SC	120	0.12	2%	45		图二	230	180	230	162	80
ACL-0150-094U-0.4SC	150	0.094	2%	55	230		180	230	162	80	11X18
ACL-0200-070U-0.4SC	200	0.07	2%	75-90	250		180	240	182	88	11X18
ACL-0250-056U-0.4SC	250	0.056	2%	110	250		190	240	182	98	11X18
ACL-0290-048U-0.4SC	290	0.048	2%	132	290		200	250	214	102	11X18
ACL-0330-042U-0.4SC	330	0.042	2%	160	290		205	260	214	107	11X18
ACL-0390-036U-0.4SC	390	0.036	2%	185	290		205	260	214	107	11X18
ACL-0490-028U-0.4SC	500	0.028	2%	200-220	320		230	300	243	102	12X20
ACL-0600-024U-0.4SC	600	0.024	2%	250-280	320		260	310	243	117	12X20
ACL-0660-022U-0.4SC	660	0.022	2%	315	320		260	310	243	117	12X20
ACL-0800-17U5-0.4SC	800	0.0175	2%	355-380	365		295	320	260	145	15X25
ACL-1000-14U0-0.4SC	1000	0.014	2%	400-450	365		300	330	260	150	15X25
ACL-1200-11U7-0.4SC	1200	0.0117	2%	500-550	365		310	435	260	160	15X25
ACL-1600-08U6-0.4SC	1600	0.0086	2%	630	365		320	435	260	160	15X25

■ 产品选择指引 (Selection guide)

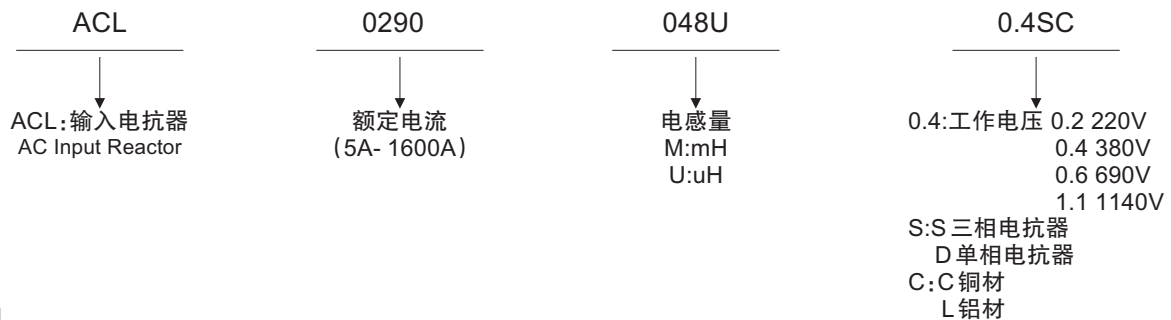

交流输出电抗器(OCL) AC Output Reactor

■ 产品概述(Product Introduction)

安装在变频器输出端,用于限制变频器与电机连接电缆的容性充电电流,钝化变频器输出的PWM波的电压上升率。电机电缆长度超过一定值时,建议在变频器与电机之间插入一个电机电抗器。用于补偿在长导线时的电容再充电电流。此最大长度决定于变频器的额定值以及电机电缆的类型。

The input reactor is mounted at the output of the frequency inverter. It is used for limiting the capacitive charging current of the connection cable between the frequency inverter and the motor, and passivating the voltage buildup rate of PWM form the frequency inverter and the motor.



■ 产品应用(Product Application)

1. 将dv/dt限制到500V/US
2. 将电机端子上的过电压限制到:1000V至400V~(rms值)1150V至460V~(rms值)
3. 打开滤波器与电机之间的接触器所引起的滤波器干扰
4. 减小电机接地泄露电流
1. Limit dv/dt to 500V/us
2. Limit the overvoltage of motor terminal to :1000V to 400V~(rms)
3. The interference occurred from the contact between the motor and the filter
4. Reduce the earth leakage current of motor

■ 技术规格(Technical Specifications)

1. 工作电压:220VAC-3300VAC
2. 工作频率:50/60Hz.
3. 额定电流:3A-1600A
4. 载波频率:2-8KHz.
5. 绝缘等级: class F,H
6. 使用环境:-10~+45°C,额定值不会降低。最高可达+55°C,在45°C以上,每升高1°C,额定电流降低2%
7. 防护等级:IP00-IP22
8. 压降:<4% 大于此范围会引起转矩损失
9. 最大电流:1.5×额定电流,持续60S
10. 噪音:≤65dB
11. 温升:≤85K
12. 抗电强度:铁芯-绕组3000VAC/50Hz/5mA/10s无飞弧击穿(工厂测试)
13. 绝缘电阻:1000VDC绝缘阻值≥100MΩ
14. 海拔高度不超过2000米
15. 运行环境温度-25°C~+45°C,相对湿度不超过90%
16. 周围无有害气体,无易燃易爆物品
17. 周围环境应有良好的通风条件,如装在柜内,应加装通风设备
1. Work voltage:220VAC-3300VAC
2. Work frequency:50/60Hz
3. Work current:3A-1600A
4. Carrier frequency:2-8KHz
5. Insulation class:class F,H
6. Operation Environment:-10°C+45°C, rated value won't lower, when higher than 45°C, and every 1°C, the current will step down 2%
7. Protection class:IP00-ip22
8. Voltage drop: < 4% higher than the range will cause the loss of torque
9. Max Current:1.5 × Rated current, continuous 60S
10. Noise:≤65dB
11. Temperature Rise:≤85K
12. Dielectric strength:Core Coil 3000VAC/50Hz/5mA/10s no electric arcing puncture(factory test)
13. Insulation Resistor:1000VDC insulation resistance value≥100MΩ
14. Under seal level 2000m
15. Running ambient temperature-25°C~+45°C, comparative moisture not over 90%
16. No hazardous gas, no inflammables and explosives
17. With well-ventilated condition, ventilation devices shall be mounted if installation in panels

■ 执行标准 (Applicable Standards)

IEC289:1987 Reactor GB10229-88 Reactor(eqvIEC289:1987)
 JB9644-1999 Reactors used for semiconductor electrical driving

■ 产品尺寸图 (Product Size)

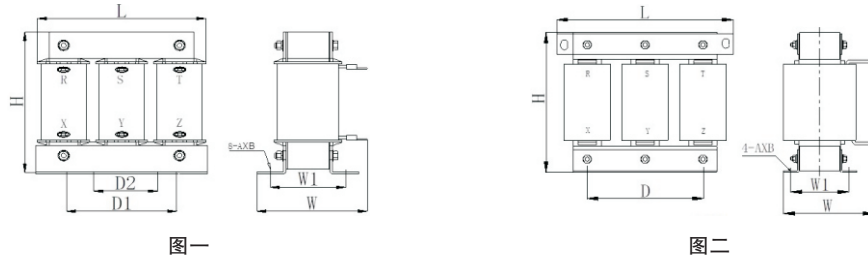

型号 Type	电流 Rated Current (A)	电感量 Induc-tance Value (mH)	压降 Voltage Drop	适配变频器功率 (KW)	图号 Picture	尺寸 Dimension(mm)					
						L (max)	W (max)	H (max)	D1 ± 2	W1 ± 3	4-AXB
OCL-0005-1M40-0.4SC	5	1.4	1%	1.5	图一	120	110	120	65	60	6X15
OCL-0008-1M00-0.4SC	8	1.0	1%	2.2		120	110	120	65	60	6X15
OCL-0010-0M70-0.4SC	10	0.7	1%	3.7		120	110	120	65	60	6X15
OCL-0015-0M47-0.4SC	15	0.47	1%	5.5		120	110	120	65	60	6X15
OCL-0020-0M35-0.4SC	20	0.35	1%	7.5		155	140	140	95	73	6X15
OCL-0030-0M23-0.4SC	30	0.23	1%	11		155	140	140	95	73	6X15
OCL-0040-0M18-0.4SC	40	0.18	1%	15		155	150	140	120	78	6X15
OCL-0050-0M14-0.4SC	50	0.14	1%	18.5		195	160	165	120	85	8.5X20
OCL-0060-0M12-0.4SC	60	0.12	1%	22		195	160	165	120	85	8.5X20
OCL-0080-087U-0.4SC	80	0.087	1%	30		195	160	175	120	85	8.5X20
OCL-0090-078U-0.4SC	90	0.078	1%	37		195	170	175	120	92	8.5X20
OCL-0120-058U-0.4SC	120	0.058	1%	45		195	180	190	120	105	8.5X20
OCL-0150-047U-0.4SC	150	0.047	1%	55		195	180	190	120	105	8.5X20
OCL-0120-058U-0.4SC	120	0.058	1%	45		图二	230	180	230	162	80
OCL-0150-047U-0.4SC	150	0.047	1%	55	230		180	230	162	80	11X18
OCL-0200-035U-0.4SC	200	0.035	1%	75-90	250		180	240	182	88	11X18
OCL-0250-028U-0.4SC	250	0.028	1%	110	250		190	240	182	98	11X18
OCL-0290-024U-0.4SC	290	0.024	1%	132	290		200	250	214	102	11X18
OCL-0330-021U-0.4SC	330	0.021	1%	160	290		205	260	214	107	11X18
OCL-0390-018U-0.4SC	390	0.018	1%	185	290		205	260	214	107	11X18
OCL-0490-014U-0.4SC	500	0.014	1%	200-220	320		230	300	243	102	12X20
OCL-0600-012U-0.4SC	600	0.012	1%	250-280	320		260	310	243	117	12X20
OCL-0660-011U-0.4SC	660	0.011	1%	315	320		260	310	243	117	12X20
OCL-0800-08U7-0.4SC	800	0.0087	1%	355-380	365		295	320	260	145	15X25
OCL-1000-00U7-0.4SC	1000	0.007	1%	400-450	365		300	330	260	150	15X25
OCL-1200-05U8-0.4SC	1200	0.0058	1%	500-550	365		310	435	260	160	15X25
OCL-1600-04U3-0.4SC	1600	0.0043	1%	630	365		320	435	260	160	15X25

■ 产品选择指引 (Selection guide)

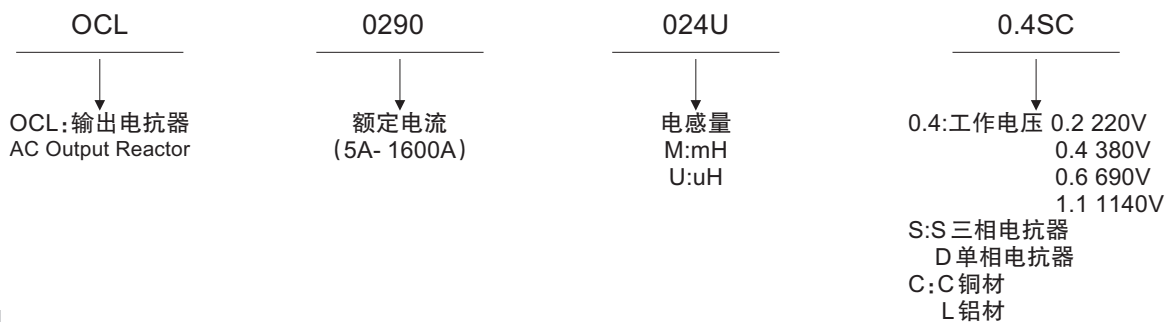

直流电抗器(DCL) DC Reactor

■ 产品概述(Product Introduction)

直流平波电抗器用于整流回路之中,抑制整流后的波纹脉动分量,并使整流后的电流连续不断,改善输出的支流波形,保证支流设备的正常运行。

DC smoothing reactor rectifier circuit being used to suppress ripple rectified pulsating component and make rectified current continuously Improve the output waveform tributaries,to ensure the normal operation of the DC devices.



■ 产品应用(Product Application)

1. 改善电容滤波造成的输入电流波形畸变。
 2. 减少和防止因冲击电流造成整流桥损坏和电容过热。
 3. 提高功率因素,降低直流母线交流脉冲。
 4. 限制电网电压的瞬变。
 5. 与并联链接的电容一起共同抑制或滤掉直流中的纹波,以排除对负载的不利影响。
1. Suppress the waveform distortion of input current caused by capacitive filtering
 2. Reduce and avoid overheat of capacity and rectifier bridge damage both of which arise from surge current
 3. Improve power factor and reduce the DC busbar AC pulse.
 4. Limit the instant change of the grid voltage
 5. Work with capacitor to suppress or filter the current ripple for eliminating negative influence on load

■ 技术规格(Technical Specifications)

1. 工作电压: 220VAC-1140VAC
 2. 工作频率: 50/60Hz.
 3. 工作电流: 3A-1600A
 4. 绝缘等级: class F, H
 5. 使用环境: -10...+45°C, 额定值不会降低。最高可达+55°C, 在45°C以上, 每升高1°C, 额定电流降低2%
 6. 防护等级: IP00-IP22
 7. 最大电流: 1.5 × 额定电流, 持续 60S
 8. 噪音: ≤65dB
 9. 温升: ≤85K
 10. 抗电强度: 铁芯-绕组 3000VAC/50Hz/5mA/10s 无飞弧击穿(工厂测试)
 11. 绝缘电阻: 1000VDC 绝缘阻值≥100MΩ
 12. 海拔高度不超过 2000 米。
 13. 运行环境温度 -25°C~+45°C, 相对湿度不超过 90%。
 14. 周围无有害气体, 无易燃易爆物品。
 15. 周围环境应有良好的通风条件, 如装在柜内, 应加装通风设备。
1. Work voltage: 220VAC-1140VAC
 2. Work frequency: 50/60Hz
 3. Work current: 3A-1600A
 4. Insulation class: class F, H
 5. Operation Environment: -10...+45°C, rated value won't lower, when higher than 45°C, and every 1°C, the current will step down 2%
 6. Protection class: IP00-IP22
 7. Max Current: 1.5 × Rated current, continuous 60S
 8. Noise: ≤65dB
 9. Temperature Rise: ≤85K
 10. Dielectric strength: Core Coil 3000VAC/50HZ/5mA/10s no electric arcing puncture(factory test)
 11. Insulation Resistor: 1000VDC insulation resistance value ≥100MΩ
 12. Under seal level 2000m
 13. Running ambient temperature -25°C~+45°C, comparative moisture not over 90%
 14. No hazardous gas, no inflammables and explosives
 15. With well-ventilated condition, ventilation devices shall be mounted if installed in panels

■ 执行标准 (Applicable Standards)

IEC289:1987 Reactor GB10229-88 Reactor(eqvIEC289:1987)
 JB9644-1999 Reactors used for semiconductor electrical driving

■ 产品尺寸图 (Product Size)

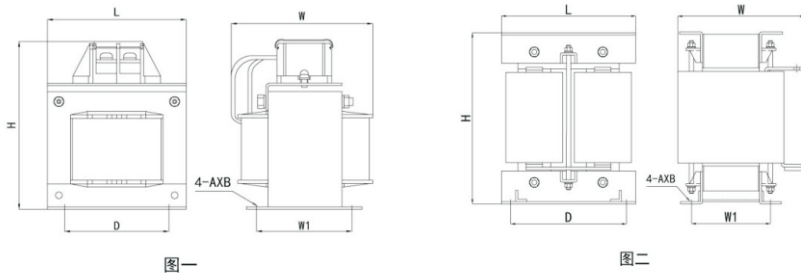

型号 Type	电流 Rated Current (A)	电感量 Induc - tance Value (mH)	适配变频 器功率 Power (KW)	图号 Picture	尺寸 Dimension(mm)					
					L (max)	W (max)	H (max)	D1 ± 2	W1 ± 3	4-AXB
DCL-0010-6M30-0.6C	10	6.3	4	图一	90	110	120	68	65	6X11
DCL-0015-3M60-0.6C	15	3.6	5.5		100	120	130	78	70	6X11
DCL-0020-3M60-0.6C	20	3.6	7.5		100	120	130	78	70	6X11
DCL-0030-2M00-0.6C	30	2	11		110	120	135	87	70	6X11
DCL-0040-1M30-0.6C	40	1.3	18.5		110	120	135	87	70	6X11
DCL-0050-1M08-0.6C	50	1.08	22		120	135	145	95	85	8.5X13
DCL-0065-0M80-0.6C	65	0.8	30		135	145	175	110	85	8.5X13
DCL-0080-0M70-0.6C	80	0.7	37		135	145	175	110	85	8.5X13
DCL-0100-0M54-0.6C	100	0.54	45		135	145	175	110	85	8.5X13
DCL-0120-0M45-0.6C	120	0.45	55		200	190	215	176	90	11X18
DCL-0160-0M36-0.6C	160	0.4	75	图二	200	190	215	176	90	11X18
DCL-0200-0M33-0.6C	200	0.33	90		200	190	215	176	90	11X18
DCL-0250-0M26-0.6C	250	0.26	110		200	225	260	176	100	11X18
DCL-0300-0M26-0.6C	300	0.26	132		200	230	260	176	105	11X18
DCL-0350-0M17-0.6C	350	0.17	160		200	235	285	176	110	11X18
DCL-0450-090U-0.6C	450	0.09	185-200		200	240	285	176	115	11X18
DCL-0500-060U-0.6C	500	0.06	220-250		240	250	310	210	120	11X18
DCL-0650-050U-0.6C	650	0.05	280-315		240	260	310	210	130	11X18
DCL-0800-050U-0.6C	800	0.05	355-380		240	270	330	210	135	11X18
DCL-1000-040U-0.6C	1000	0.04	400-450		240	280	330	210	140	11X18

■ 产品选择指引 (Selection guide)

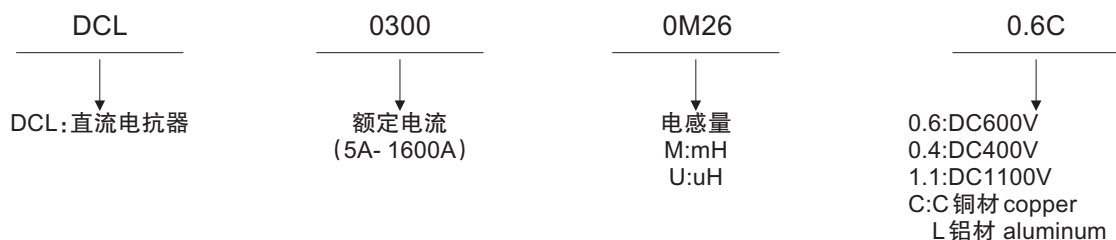

DV/DT 滤波器 (VTR) dvdt Filter



■ 产品概述 (Product Introduction)

PWM 逆变器直接驱动电机时会产生较高 dv/dt 的共模电压, 并由此产生轴承电流和共模漏电流以及严重的电磁干扰 (EMI), 特别是当逆变器通过长电缆与电机连接时, 由于电缆中分布参数的影响, 会在电机端产生电压反射现象, 从而在电机端会产生 2 倍以上的过电压, 导致线圈绝缘失败, 我们的 dv/dt 滤波器降低电机电缆传输线效应电压的增大而衰减率, 并最大限度地减少在电机端子上所发生的峰值电压。

When the PWM inverter will produce high common mode voltage of dv/dt when directly driving the motor, resulting in bearing current and common-mode leakage current as well as severe electromagnetic interference (EMI). Especially when the inverter is connected to the motor with a long cable, the influence of the distribution parameters of the cable will result in voltage reflection, which will produce over-voltage of over two times at the motor terminal, causing failure of the coil insulation. However, our dv/dt filters can reduce the rate of decay due to increase of the effect voltage during transmission of the motor cable, and minimize the peak voltage generated at the motor terminal.

■ 产品应用 (Product Application)

1. 有效降低变频伺服电动机端的 dv/dt 电压;
2. 防止传输电缆和伺服电机线圈的过早老化和击穿;
3. 延长伺服电机的使用寿命, 提高伺服的可靠性和正常运行时间;
4. 降低对邻近设备或线路的干扰传播;
5. 减小电机接地泄露电流
6. 减小打开滤波器与电机之间的接触器所引起的干扰
1. effectively reducing the dt/dv voltage of the inverter servo motor ends;
2. preventing the transmission cable and the servo motor coil from early aging and breakdown;
3. extending the service life of the servo motors and operation period and improving the servo's reliability;
4. reducing the interference to the nearby equipment and circuits;
5. reducing the motor grounding leaking current;
6. reducing the interference when the contactor between filters and the motors is switched on;

■ 技术规格 (Technical Specifications)

1. 最大工作电压: 400V AC-1140V AC
2. 额定电流: 5~500A
3. 频率: 50-60Hz
4. 开关频率: 2~8KHz
5. 防护等级: IP00-IP20
6. 绝缘等级: class F, H
7. 使用环境: $-10^{\circ}+45^{\circ}\text{C}$, 额定值不会降低。最高可达 $+55^{\circ}\text{C}$, 在 45°C 以上, 每升高 1°C , 额定电流降低 2%
8. 最大电缆长度: 1000m
9. 最大电流: $1.5 \times$ 额定电流, 持续 60S
10. 噪音: $\leq 65\text{dB}$
11. 温升: $\leq 70\text{K}$
12. 抗电强度: 铁芯-绕组 3000VAC/50HZ/5MA/10S 无飞弧击穿 (工厂测试)
13. 绝缘电阻: 1000VDC 绝缘阻值 $\geq 100\text{M}\Omega$
1. Work Voltage: 220VAC-1140VAC
2. Work Current: 5A-500A
3. Work Frq: 50/60HZ
4. Switching frequenc: 2~8KHZ
5. Protection class: IP00-IP22
6. Insulation Class: class F, H
7. Operation Environment: $-10^{\circ}+45^{\circ}\text{C}$, rated value won't lower, when higher than 55°C , and every 1°C , the current will step down 2%
8. Maximum cable length: 1000m
9. Max Current: $1.5 \times$ Rated current, continuous 60s
10. Noise: $\leq 65\text{dB}$
11. Temperature Rise: $\leq 70\text{K}$
12. Dielectric strength: Core Coil 3000VAC/50HZ/5MA/10s no electric arcing puncture (factory test)
13. Insulation Resistor: 1000VDC insulation resistance value $\geq 100\text{M}\Omega$

■ 产品尺寸图 (Product Size)

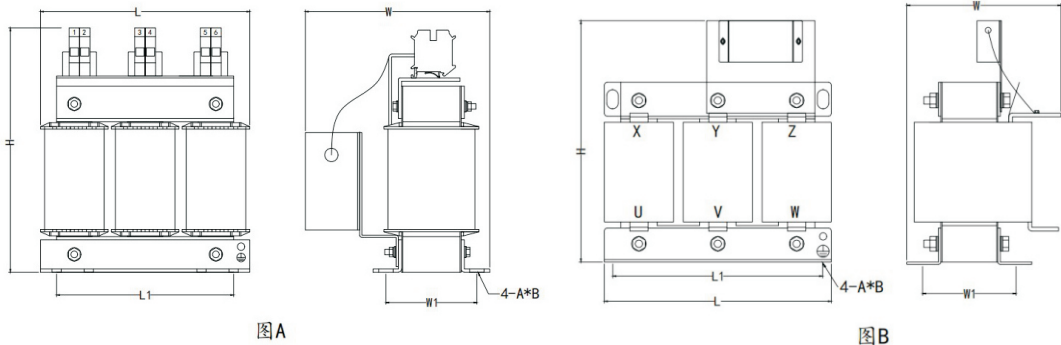

型号 Type	电流 Rated Current (A)	适配变频器功率 Power (KW)	载波频率 Carrier Frequency	重量 Weight	图号 Picture	尺寸 Dimension(mm)					
						L (max)	W (max)	H (max)	L1 ± 2	W1 ± 3	4-AXB
VTR-0010-0.4SL	10	3.7	4	5.5	图 A	150	140	190	137	66	6X11
VTR-0015-0.4SL	15	5.5	4	5.6		150	140	190	137	66	6X11
VTR-0020-0.4SL	20	7.5	4	5.7		150	140	190	137	66	6X11
VTR-0030-0.4SL	30	11	4	6.5		180	140	220	165	67	8X14
VTR-0040-0.4SL	40	15	4	6.8		180	140	220	165	67	8X14
VTR-0050-0.4SL	50	18.5	4	9.5		180	160	220	165	87	8X14
VTR-0060-0.4SL	60	22	4	9.7		180	160	220	165	87	8X14
VTR-0080-0.4SL	80	30	3	12.4	图 B	180	150	250	165	97	8X14
VTR-0090-0.4SL	90	37	3	14.9		230	140	250	210	80	8X14
VTR-0120-0.4SL	120	45	3	15		230	140	250	210	80	8X14
VTR-0150-0.4SL	150	55	3	17.5		230	150	250	210	90	8X14
VTR-0200-0.4SL	200	75-90	3	25		230	180	280	210	105	8X14
VTR-0250-0.4SL	250	110	2	35		270	195	310	245	121	11X18
VTR-0290-0.4SL	290	132	2	40.5		270	205	355	245	126	11X18
VTR-0330-0.4SL	330	160	2	45		270	215	355	245	136	11X18
VTR-0390-0.4SL	390	185	2	52		300	225	370	275	159	11X18
VTR-0490-0.4SL	490	220	2	56.6		300	240	370	275	164	11X18
VTR-0600-0.4SL	600	250-280	2	75.5		350	240	390	325	164	11X18
VTR-0660-0.4SL	660	315	2	76		350	240	390	325	164	11X18
VTR-0800-0.4SL	800	355-380	2	82.3		350	250	390	325	174	11X18
VTR-1000-0.4SL	1000	400-450	2	119	420	280	470	310	162	13X23	
VTR-1200-0.4SL	1200	500-550	2	134	420	280	520	310	162	13X23	

■ 产品选择指引 (Selection guide)

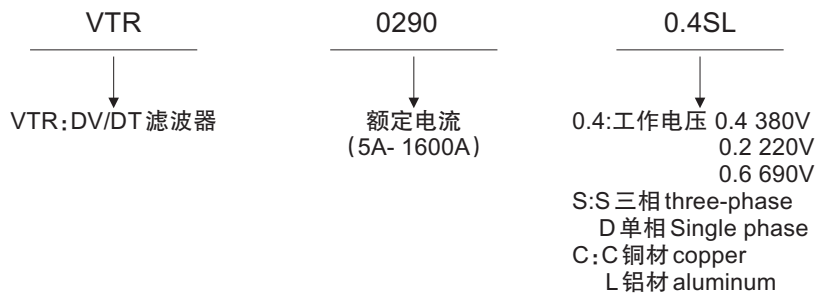

正弦波滤波器(FRS) Sine Wave Filter

■ 产品概述(Product Introduction)

正弦波滤波器是在 PWM 变频器驱动下,其开关频率范围在 2–8KHz 之间仍提供正弦波输出电压。在变频器驱动应用中,这种滤波器可以消除电机绝缘失败问题并通过消除与变频器输出波形相关的高 dv/dt 来减少电磁干扰,改善电机的性能和寿命,延长变频器输出距离,最长可达 3KM。

Driven by the PWM inverter,the sine filter still provides sine wave output voltage when the switching frequency range is within the range of 2–8KHZ,In the applications of inverter drives,such a filter can eliminate the problem of motor insulation failure and decrease electromagnetic interference by eliminating the high dv/dt related to inverter output waveform,so as to extend the life and improve the performance of the motor,and extend the output length of the inverter to up to 3KM.

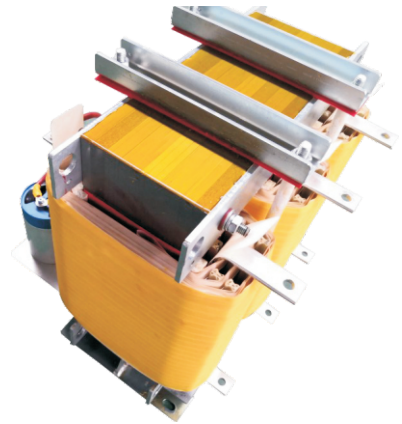

■ 产品应用(Product Application)

1. 将变频器输出的 PWM 波转换为正弦波
 2. 降低电机的涡流损耗以及电机噪声
 3. 减少输出电缆上和电机中的脉冲电流,延长电机寿命
 4. 可在变频器与电机间使用更长的电缆连线
 5. 减小对外的辐射,在一定场合可以使用非屏蔽电缆,降低了对现场布线的要求
 6. 有效防止高 DV/DT、过电压、电机过热和涡流损耗造成的电机提前损坏。
- 1.Convert the PWM waves output by the inverter sine waves
 - 2.Reduce the eddy current losses of the motor and the motor noise
 - 3.Reduce the pulse current of the output cable and motor,extending the life of the motor
 - 4.A longer cable wire can be used between the inverter and motor
 - 5.Reduce the external radiation,by using unshielded cable in certain situations,lowering
 - 6.Effectively prevent fatigue of the motor caused by high DV/DT,over voltage,motor heating and eddy current loss.

■ 技术规格(Technical Specifications)

1. 工作电压: 220VAC–690VAC
 2. 工作电流: 15A–1500A
 3. 工作频率: 50/60Hz
 4. 载波频率: 2K–8K
 5. 绝缘等级: class F,H
 6. 压降: 8%–12%
 7. 中压谐波畸变失真 THD≤5%
 9. 使用环境: –10...+45℃,额定值不会降低。最高可达+55℃,在 45℃以上,每升高 1℃,额定电流降低 2%
 12. 噪音: ≤65dB
 13. 温升: ≤70K
 14. 抗电强度: 铁芯–绕组 3000VAC/50Hz/5mA/10s 无飞弧击穿(工程测试)
 15. 绝缘电阻: 1000VDC 绝缘阻值≥100MΩ
 16. 海拔高度不超过 2000 米。
- 1.Work Voltage:220VAC–690VAC
 - 2.Work Current:15A–1500A
 - 3.Work Frequency:50/60Hz
 - 4.Switching frequency:2~8KHZ
 - 5.Insulation Class:class F,H
 - 6.Rated voltage drop:8~12%
 - 7.Voltage harmonic distortion:THD≤5%
 - 9.Operation Environment:–10~+45℃,rated value won't lower,when higher than 55℃,and every 1℃,the current will step down 2%
 - 12.Noise:≤65dB
 - 13.Temperature Rise:≤70K
 - 14.Dielectric strength:Core Coil 3000VAC/50HZ/5mA/10S no electric arcing puncture(factory test)
 - 15.Insulation Resistor:1000VDC insulation resistance value≥100MΩ
 - 16.Under seal level 2000m

■ 产品尺寸图(Product Size)

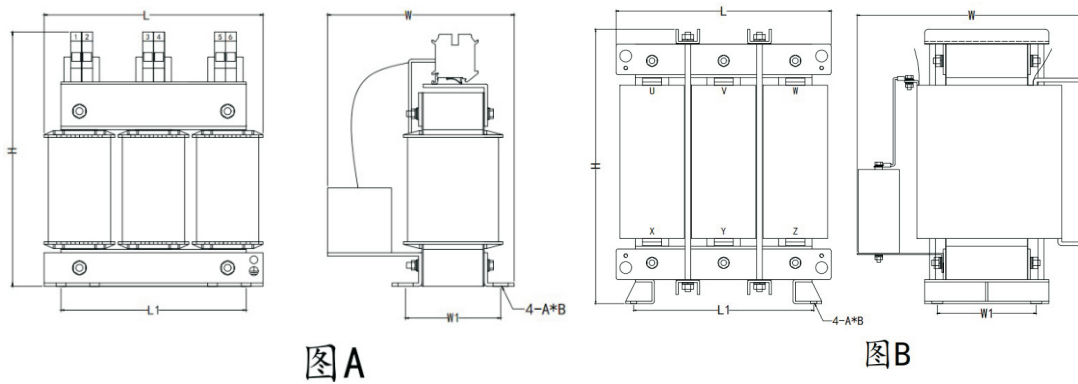

型号 Type	电流 Rated Current (A)	适配变频器功率 Power (KW)	载波频率 Carrier Frequency	重量 Weight	图号 Picture	尺寸 Dimension(mm)					
						L (max)	W (max)	H (max)	L1 ± 2	W1 ± 3	4-AXB
FRS-0005-0.4SL	5	1.5	4	6	图 A	180	170	220	165	67	8X14
FRS-0008-0.4SL	8	2.2	4	6.5		180	170	220	165	67	8X14
FRS-0010-0.4SL	10	3.7	4	9.8		180	190	220	165	87	8X14
FRS-0015-0.4SL	15	5.5	4	10		180	190	220	165	87	8X14
FRS-0020-0.4SL	20	7.5	4	11.7		180	200	220	165	95	8X14
FRS-0030-0.4SL	30	11	4	19		230	240	245	210	78	8X14
FRS-0040-0.4SL	40	15	4	20		230	240	245	210	78	8X14
FRS-0050-0.4SL	50	18.5	4	25.5		270	240	300	245	99	11X18
FRS-0060-0.4SL	60	22	4	31.5		270	255	300	245	114	11X18
FRS-0080-0.4SL	80	30	3	37		270	265	300	245	114	11X18
FRS-0090-0.4SL	90	37	3	48	图 B	300	315	300	275	144	11X18
FRS-0120-0.4SL	120	45	3	52.5		300	320	300	275	149	11X18
FRS-0150-0.4SL	150	55	3	57.6		300	330	300	275	159	11X18
FRS-0200-0.4SL	200	75-90	3	98		350	360	365	275	184	11X18
FRS-0250-0.4SL	250	110	2	133		450	390	470	377	167	13X23
FRS-0290-0.4SL	290	132	2	145		450	400	470	377	167	13X23
FRS-0330-0.4SL	330	160	2	178		450	440	530	377	207	13X23
FRS-0390-0.4SL	390	185	2	193		450	450	530	377	207	13X23
FRS-0490-0.4SL	490	220	2	208		450	480	530	377	207	13X23
FRS-0600-0.4SL	600	250-280	2	264		450	490	630	377	207	13X23
FRS-0660-0.4SL	660	315	2	298		480	490	650	407	207	13X23
FRS-0800-0.4SL	800	355-380	2	337		480	530	650	407	247	13X23
FRS-1000-0.4SL	1000	400-450	2	418.5	540	590	730	457	247	13X23	
FRS-1200-0.4SL	1200	500-550	2	529	540	610	830	457	247	13X23	

■ 产品选择指引 (Selection guide)

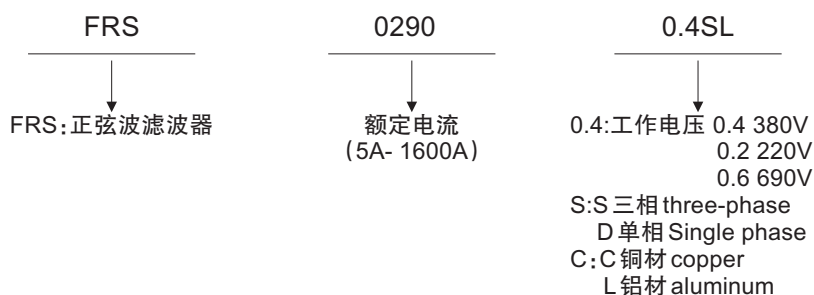

谐波滤波器(HFL) Harmonic Filter

■ 产品概述(Product Introduction)

1. 与传统谐波陷波滤波器相比,HFL系列产品占用面积更小,谐波抑制能力更强。提升了电气装置的可靠性,延长了使用寿命,有助于更好的利用电力系统的容量,对于达到IEEE519等电力质量标准具有更重要意义。

2. 效率超过98%,功率可到250KW,无源谐波滤波器提供了具有高性价比和坚固耐用的谐波解决方案。能够长期节约系统运营和维护成本,有助于节能减排。

3. 作为独立选项,HFL谐波滤波器采用即插即用方法,其结构比同类产品更紧凑,易于安装到现有的安装面板内,可以快速安装和方便调试。因此,特别适合因变频器的位置调整受到限制的项目改造应用场合。

1. Compared with traditional harmonic notch filter, HFR series products occupy less area and have stronger harmonic suppression ability. It improves the reliability of electrical devices, prolongs the service life, helps to make better use of the capacity of the power system, and has more important significance for reaching IEEE519 and other power quality standards.

2. With an efficiency of over 98% and power up to 250KW, passive harmonic filters provide a cost-effective and rugged harmonic solution. Can save the system operation and maintenance for a long time, contribute to energy conservation and emission reduction.

3. As an independent option, HFL harmonic filter adopts plug and play method, its structure is more compact than similar products, easy to install into the existing mounting panel, can be quickly installed and easy to debug. Therefore, it is especially suitable for the application of project transformation where the adjustment of inverter's position cap is limited.



■ 技术规格(Technical Specifications)

1. 额定工作电压: AC380V~480V

2. 频率: 50Hz

3. 过载能力: 1.6倍, 60s

4. 绝级等级: 过压类别III符合EN61800-5-1

5. 满载效率: 大于98%

6. 冷却方式: AN

7. 谐波滤波效果: 满载条件下, 滤波器输入端的总谐波电流畸变率THID < 10% 背景电压THUD < 2%

8. 环境温度(工作): 满载条件下, -25°C~+50°C

9. 存储温度: -25°C~65°C

10. 工作海拔高度: 海拔0~2000米

11. 相对湿度: 0~95% 无凝露

12. 空载电流: 小于额定电流的35%

13. 产品执行标准: IEEE519 GB/T 14549-1993

1. Rated working voltage: AC380V~480V

2. Frequency: 50Hz

3. Overload capacity: 1.6 times, 60s

4. Absolute grade grade: overpressure class iii in accordance with EN61800-5-1

5. Full load efficiency: more than 98%

6. Cooling method: AN

7. Harmonic filtering effect: under the condition of full load, the total harmonic current distortion rate of the filter input terminal THID < 10% and the background voltage THUD < 2%

8. Ambient temperature (working) : -25°C~+50°C under full load

9. Storage temperature: -25°C~65°C

10. Working altitude: 0~2000 meters

11. Relative temperature: 0~95% no condensation

12. No-load current: less than 35% of rated current

13. Product standard: IEEE519 GB/T 14549-1993

■ 产品尺寸图(Product Size)

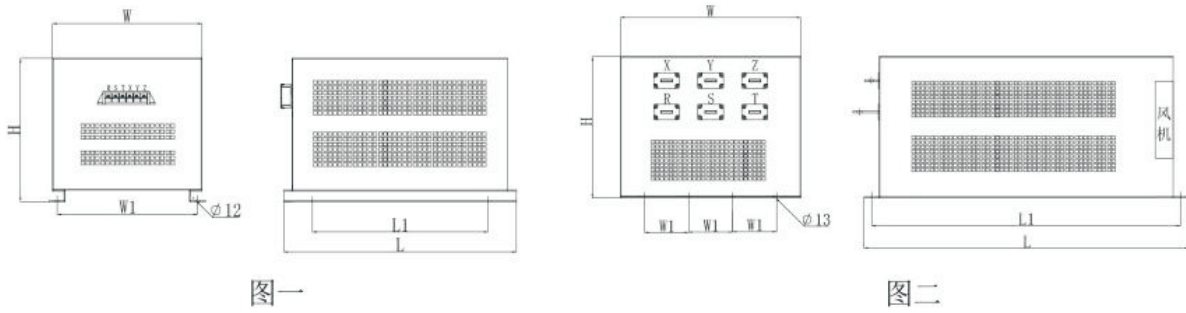

型号 Type	电流 Rated Current (A)	适配变频器 功率 Power (KW)	图号 Picture	绝缘等级 Insulation class	尺寸 Dimension(mm)				
					L(max)	W(max)	H(max)	L1 ± 2	W1 ± 3
HFL-0005-A10	5	1.5	图一	F、H	350	235	220	280	215
HFL-0007-A10	7	2.2		F、H	350	235	220	280	215
HFL-0010-A10	10	3.7		F、H	350	235	220	280	215
HFL-0020-A10	20	7.5		F、H	350	235	220	280	215
HFL-0030-A10	30	11		F、H	420	275	250	385	255
HFL-0040-A10	40	15		F、H	420	275	250	385	255
HFL-0050-A10	50	18.5		F、H	580	350	290	550	330
HFL-0060-A10	60	22		F、H	580	350	290	550	330
HFL-0080-A10	80	30		F、H	620	380	315	580	350
HFL-0090-A10	90	37		F、H	620	380	315	580	350
HFL-0120-A10	120	45		F、H	620	380	315	580	350
HFL-0150-A10	150	55		F、H	620	380	315	580	350
HFL-0200-A10	200	75	图二	F、H	950	455	335	920	175
HFL-0250-A10	250	110		F、H	950	455	335	920	175
HFL-0290-A10	290	132		F、H	950	455	335	920	175
HFL-0330-A10	330	160		F、H	1060	495	365	1030	125
HFL-0390-A10	390	185		F、H	1060	495	365	1030	125
HFL-0490-A10	490	220		F、H	1060	495	365	1030	125
HFL-0600-A10	600	280		F、H	1060	495	365	1030	125

■ 产品选择指引 (Selection guide)

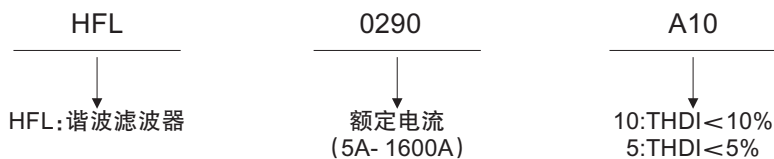

输入滤波器(NFI) Input Filter

产品概述(Product Introduction)

变频器在现代工业中已经得到广泛应用,对电网造成了严重的谐波污染,并给周围的电器设备造成严重的电磁干扰。变频器加装输入滤波器后,能有效抑制变频器对电网及负载的传导干扰,降低输入/输出导线对外辐射干扰。

Frequency converter has been widely used in modern industry, causing serious harmonic pollution to power grid and serious electromagnetic interference to the surrounding electrical equipment. After the inverter is equipped with input filter, it can effectively suppress the conduction interference of the inverter to the power grid and load, and reduce the external radiation interference of the input/output wire.



技术规格(Technical Specifications)

1. 额定电压: AC220-1140V
2. 工作频率: 50Hz
3. 额定电流: 5A-1200A
4. 温度范围: -25℃~100℃ (25/100/21)
5. 设计依据: IEC/EN 60939
6. 典型滤波频率: 150KHz~30MHz

1. Rated voltage: 440/250 VAC
2. Operating frequency: 50Hz
3. Rated current: 5A~1000A
4. Temperature range: -25℃~100℃ (25/100/21)
5. Temperature range: IEC/EN 60939
6. Typical work frequency: 150KHz~30MHz

产品尺寸图(Product Size)

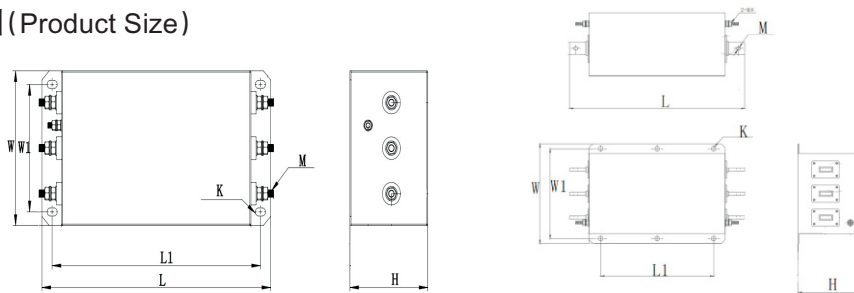

型号 Type	电流 Rated Current (A)	适配变频器功率 Power (KW)	图号 Picture	尺寸 Dimension(mm)						
				L(max)	W(max)	H(max)	L1 ± 2	W1 ± 2	K ± 2	M
NFI-0005	5	1.5-2.2	图一	140	93	56	125	70	5X7	M4
NFI-0010	10	3.7		140	93	56	125	70	5X7	M4
NFI-0020	20	5.5-7.5		186	108	60	168	85	6X9	M6
NFI-0030	30	11-15		186	108	60	168	85	6X9	M6
NFI-0050	50	18.5-22		240	125	80	220	100	6X9	M6
NFI-0065	65	30		240	125	80	220	100	6X9	M6
NFI-0080	80	37		314	175	107	286	140	8X14	M8
NFI-0100	100	45		314	175	107	286	140	8X14	M8
NFI-0120	120	55		314	175	107	286	140	8X14	M8
NFI-0150	150	75		354	185	185	326	150	8X14	M10
NFI-0200	200	90	354	185	185	326	150	8X14	M10	
NFI-0250	250	110	354	185	185	326	150	8X14	M10	
NFI-0300	300	132	图二	394	256	115	240	230	6X12	M10
NFI-0420	420	160-220		394	256	115	240	230	6X12	M10
NFI-0500	500	250		444	256	162	290	230	6X12	M10
NFI-0600	600	280-315		444	256	162	290	230	6X12	M10
NFI-0800	800	355-400		475	256	162	290	230	6X12	M10
NFI-1000	1000	450-500		475	256	162	290	230	6X12	M10
NFI-1200	1200	550-630		475	256	162	290	230	6X12	M10

产品选择指引(Selection guide)

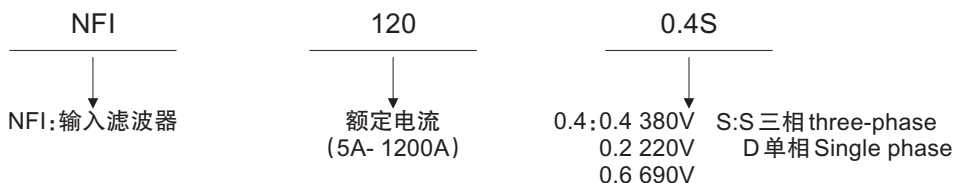

输出滤波器(NFO) Output Filter



产品概述(Product Introduction)

变频器在整流逆变过程中会产生很多谐波,这些电磁谐波会让负载端发热,严重时会导致电机烧毁。输出滤波器具有一定DV/DT谐波抑制效果,能有效减少变频器输出测的电磁干扰。

Inverter in the rectification and inverter process will produce a lot of harmonics, these electromagnetic harmonics will make the load end heat, serious will lead to motor burn. The output filter has a certain DV/DT harmonic suppression effect and can effectively reduce the electromagnetic interference of the inverter output measurement.

技术规格(Technical Specifications)

1. 额定电压: AC220-1140V
2. 工作频率: 50Hz
3. 额定电流: 5A-1200A
4. 温度范围: -25°C~100°C (25/100/21)
5. 设计依据: IEC/EN 60939
6. 典型滤波频率: 150KHz~30MHz

1. Rated voltage: 440/250 VAC
2. Operating frequency: 50Hz
3. Rated current: 5A~1000A
4. Temperature range: -25°C~100°C (25/100/21)
5. Temperature range: IEC/EN 60939
6. Typical work frequency: 150KHz~30MHz

产品尺寸图(Product Size)

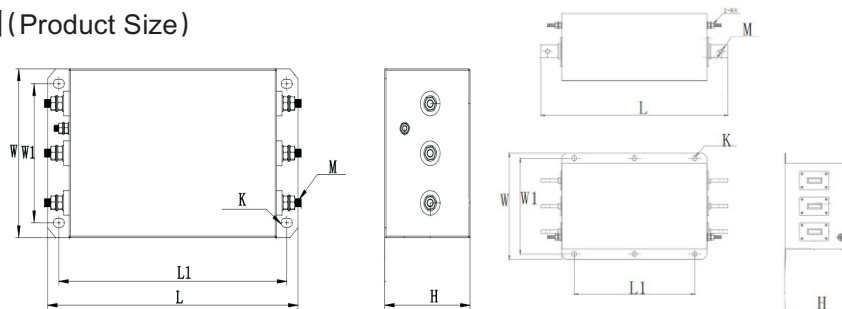

型号 Type	电流 Rated Current (A)	适配变频器功率 Power (KW)	图号 Picture	尺寸 Dimension(mm)						
				L(max)	W(max)	H(max)	L1 ± 2	W1 ± 2	K ± 2	M
NFO-0005	5	1.5-2.2	图一	140	93	56	125	70	5X7	M4
NFO-0010	10	3.7		140	93	56	125	70	5X7	M4
NFO-0020	20	5.5-7.5		186	108	60	168	85	6X9	M6
NFO-0030	30	11-15		186	108	60	168	85	6X9	M6
NFO-0050	50	18.5-22		240	125	80	220	100	6X9	M6
NFO-0065	65	30		240	125	80	220	100	6X9	M6
NFO-0080	80	37		240	125	80	220	100	6X9	M6
NFO-0100	100	45		314	175	107	286	140	8X14	M8
NFO-0120	120	55		314	175	107	286	140	8X14	M8
NFO-0150	150	75		314	175	107	286	140	8X14	M8
NFO-0200	200	90		354	185	185	326	150	8X14	M10
NFO-0250	250	110		354	185	185	326	150	8X14	M10
NFO-0300	300	132	图二	394	256	115	240	230	6X12	M10
NFO-0420	420	160-220		394	256	115	240	230	6X12	M10
NFO-0500	500	250		444	256	162	290	230	6X12	M10
NFO-0600	600	280-315		444	256	162	290	230	6X12	M10
NFO-0800	800	355-400		475	256	162	290	230	6X12	M10
NFO-1000	1000	450-500		475	256	162	290	230	6X12	M10
NFO-1200	1200	550-630		475	256	162	290	230	6X12	M10

产品选择指引(Selection guide)

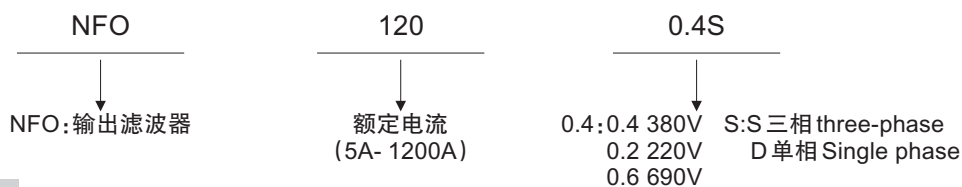

机架式负载箱(RLU) Rack type Load Bank



■ 产品概述 (Product Introduction)

机架式负载箱广泛用于数据中心,用于模拟服务器的发热,用于检测整体电力系统的带载情况;空调的制冷效果等;操作简易、体积小、运输方便。可视负荷容量大小。控制方式为手动控制方式。与传统水负荷和波纹电阻负载箱相比,无漏电、不产生有害气体和废水。负荷测试精度高,冷态热态偏差大,调节更容易,无需测试准备时间,可连续长期使用等诸多优越性。

Rack-type load box is widely used in data center, which is used to simulate the server heating, to detect the load of the whole power system, the cooling effect of air conditioning, etc. . Simple operation, small size, convenient transportation. Visual load capacity. The control mode is manual control mode. Compared with the traditional water load and ripple resistance load box, no leakage, no harmful gas and waste water. Load test precision is high, cold and hot state deviation is large, adjustment is easier, no test preparation time, can be used continuously for a long time and many other advantages.

■ 产品应用 (Product Application)

- 1、体积小:集成度高,便于携带和移动;
 - 2、精度高:采用不锈钢合金电阻,温漂小;
 - 3、安全性高:带有过热保护和过流保护;
 - 4、可靠性高:模块化设计,便于后期维护。
- 1.Small Size: High Integration, easy to carry and move
 - 2.High precision: Using stainless steel alloy resistance, small temperature drift
 - 3.High Safety: With over-heat protection and over-current protection
 - 4.High reliability: Modular design, easy to maintain

■ 技术规格 (Technical Specifications)

1. 额定电压: AC220V/DC24V/DC270V 等
 2. 额定功率: 1KW-8KW
 3. 功率因数: 1.0
 4. 控制方式: 手动控制
 5. 散热方式: 风冷
 6. 精度: 3%
 7. 工作环境: -10-55℃
 8. 防护等级:
- 1.Rated voltage: AC220VDC24VDC270V, etc.
 - 2.Rated Power: 1KW-8KW
 - 3.Power Factor: 1.0
 - 4.Control Mode: Manual Control
 - 5.Cooling Mode: air-cooled
 - 6.Accuracy: 3%
 - 7.Working Environment: -10-55 °C
 - 8.Protection level: IP20

■ 产品选择指引 (Selection guide)

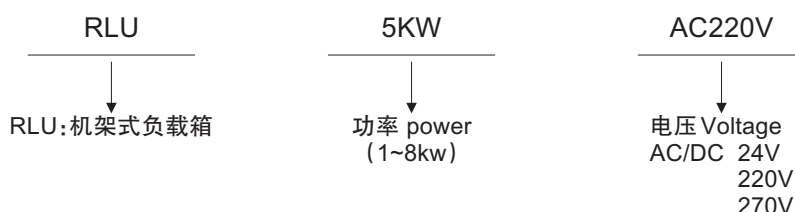

大功率负载箱(RLU) High Power Load Bank

■ 产品概述(Product Introduction)

大功率负载箱是一种电源检测设备,广泛应用于发电机、UPS、新能源汽车控制器、数据中心、银行、医院等功率电源设备的测试及维护。负载箱的使用避免了电源设备启动失败造成的经济损失,也为新机组带载能力的检测提供了科学依据。

High power load box is a kind of power testing equipment, which is widely used in testing and maintenance of generator, UPS, New Energy Vehicle Controller, Data Center, bank, hospital and other power equipment. The use of the load box avoids the economic loss caused by the failure of starting the power supply equipment, and provides a scientific basis for the load carrying capacity test of the new unit.



■ 产品应用(Product Application)

1、优越的操控性

负载箱可以通过手动旋钮,也可以通过PLC自动控制。进行负载投入容量的调整,从而大大提高了工作效率。

2、灵活的扩展性

系统具有灵活的可扩展性,阻性负载、感性负载、容性负载可以兼容组合;

3、高可靠的稳定性

电阻管是我公司独自研发定型的温度系数低,低阻抗的电阻管。材料选用的是耐盐雾耐酸碱的合金钢管和不锈钢散热片材料,因而可以保证产品的质量和长期连续工作性能。

加卸载测试时精度 $\pm 3\%$,精度高优于其它阻性负载;

4、安全性高

有接触器+断路器的双重保护;

带有风机启动及安全保护功能;

1.Superior maneuverability

The load box can be controlled by manual knob or by Plc.. Carry on the load input capacity adjustment, thus greatly enhanced the work efficiency.

2.Flexible extensibility

The system has flexible scalability, and the combination of resistive load, inductive load and capacitive load can be compatible

The load box can be connected in parallel, and the operation is convenient and reliable

3.High reliable stability

The resistance tube is a low temperature coefficient and low impedance resistance tube developed by our company.

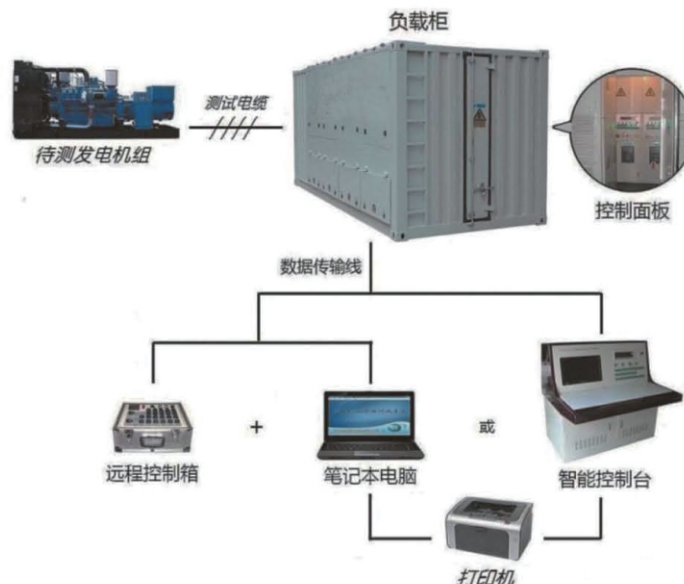

The material is alloy steel tube and stainless steel radiator material which is salt-fog and acid-alkali resistant, so the product quality and long-term continuous working performance can be guaranteed.

The accuracy of loading and unloading test is $\pm 3\%$, which is better than that of other resistive loads

4.High Security

Double protection with contactor and circuit breaker

With Fan start-up and safety protection function

■ 技术规格(Technical Specifications)

- 1.额定电压: 24V—10KV AC/DC
- 2.额定功率: 10KW—3000KW
- 3.功率因数: 0—1.0
- 4.控制方式: 手动控制/自动控制/远程控制
- 5.散热方式: 风冷
- 6.精度: 3%
- 7.工作环境: -10—55℃
- 8.防护等级: IP20—54 IP20
- 1.Rated Voltage: 24V -10kv AC/DC
- 2.Rated Power: 10kw- 3000kw
- 3.Power Factor: 0 -1.0
- 4.Control Mode: manual/automatic/remote control
- 5.Cooling Mode: air-cooled
- 6.Accuracy: 3%
- 7.Working Environment:-10-55 °C
- 8.Protection level: IP20

■ 产品尺寸图(Product Size)

类型 Type	容量 Power(KW)	尺寸 Dimension(mm)
		长*宽*高 L*W*H
柜式负载 Cabinet load Bank	≤20KW	700*500*700
	20-30KW	700*500*1200
	30-50KW	700*700*1200
	60-100KW	900*900*1200
	120-250KW	800*1000*1350
	300-500KW	1200*1400*1700
	800-1200KW	1200*2200*2200
集装箱式负载 Container type load Bank	2000KW	2438*2591*4000
	2500KW	2438*2591*5000
	3000KW	2438*2591*6000

■ 产品选择指引 (Selection guide)

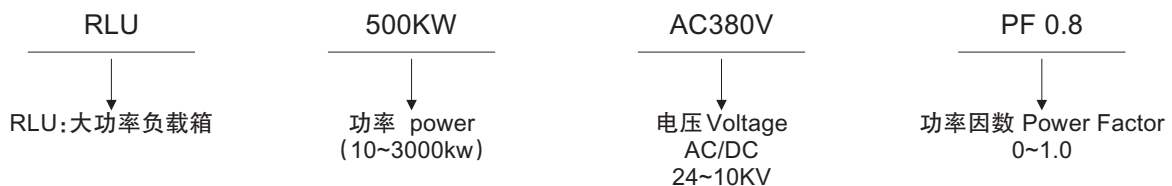

为国内外知名厂商配套服务

Supporting services for well-known manufacturers at home and abroad

SIEMENS

Schneider
Electric

ABB

Danfoss

YASKAWA

三菱电机
MITSUBISHI ELECTRIC

FUJIFILM

Inovance

invvt

HUAWEI

GDS 万国数据

amazon

Alibaba Group
阿里巴巴集团

Tencent
腾讯

SHENZHEN K-EASY AUTOMATION CO.,LIMITED

📍 Shenzhen Office Address:

8407, Xixiang Innovation Park, Qianmu Property,
80 meters east of the intersection of Baoan Avenue
Auxiliary Road and Tongda Road, Baoan District,
Shenzhen Zip code 518102

Tel: +86-0755-27850411

E-mail: Sales@keasyautomation.com

📍 Hunan Factory Address:

5th Floor, Building 1#, Auto Science and
Technology Park, No. 13, Huanlian Road,
Changsha High-tech Development Zone,
Hunan Province

Wechat/Whats App: +86-19924552818

<http://www.keasyautomation.com>

Design date: October 25, 2023

Version
1.0